

## Contents

---

This User's Manual provides operating information for the SC Series Fiber Optic Switch. The information is contained in the following sections:

- Safety**
- General Information and Specifications**
- Getting Started**
- Operating and Maintenance Instructions**
- Programming Guide**
- Customized Features and Test Data**

---

*For sales and service information,  
contact JDS FITEL or your local representative.*

**JDS FITEL Inc.**  
570 West Hunt Club Road  
Nepean, Ontario, Canada  
K2G 5W8  
Phone: (613) 727-1303  
Fax: (613) 727-8284  
E-mail: [sales@jdsfitel.com](mailto:sales@jdsfitel.com)  
Website: <http://www.jdsfitel.com>



**SC SERIES  
FIBER OPTIC SWITCH**

**User's Manual**

Model Number: SC10201+17AF000FA

Serial Number: MC013832

## **PRODUCT WARRANTY**

JDS FITEL Inc. ("JDS") warrants only to the original Buyer that all products made by JDS are free from defects in material and workmanship for a period of one (1) year from the date of shipment. The Furukawa Electric Co., Ltd. ("FEC") and Seikoh Giken Co., Ltd. ("SG") guarantee their products sold by JDS, to be free from defects in material and workmanship for a period of one (1) year from the date of shipment from JDS. All other products sold by JDS as distributor carry only the original manufacturer's warranty. Under warranty, JDS will repair or replace at its sole option, products made by it, which upon inspection by JDS and in the sole opinion of JDS, are determined to be defective in workmanship or material. JDS will accept for repair, replacement or credit under warranty products made by FEC and SG, and products made by third parties if authorized to do so. All products repaired or replaced under warranty are only warranted for the remaining unexpired period of time in the original warranty for the particular defective product. JDS, FEC and SG all reserve the right, at their sole option, to issue a credit note for any defective product as an alternative to repair or replacement. These warranties shall extend to all products which have proved defective through normal use, but excludes and does not cover any products or parts thereof which have been accidentally damaged, disassembled, modified, misused, used in applications which exceed their specifications or ratings, neglected, improperly installed or otherwise abused. Buyer must claim under the warranty in writing not later than thirty (30) days after the claimed defect is discovered. All claims under this warranty must be made by the Buyer and no claim will be accepted from any third party.

JDS will only accept returns for which an approved Return Material Authorization (RMA) has been issued by JDS. Defective products shall be returned prepaid and insured to JDS at the address shown herein. All products which have been returned to JDS but which are found to meet all previously applicable specifications for such products, shall be subject to JDS' standard examination charge in effect at the time, which shall be charged to the Buyer. All products returned to JDS which are not accompanied by an itemized statement of defects, shall be returned to the Buyer at the Buyer's expense and no evaluation of such products shall be carried out by JDS.

SD000031 Rev. E 06/03/96

**JDS FITEL Inc.**  
**570 West Hunt Club Road, Nepean, Ontario, Canada K2G 5W8**  
**Sales Inquiries: (613) 727-1303 • General Inquiries: (613) 727-1304**  
**Fax: (613) 727-8284 • E-mail: [sales@jdsfitel.com](mailto:sales@jdsfitel.com)**

# Safety Information, Instructions and Symbols

---

## Safety Information

### **Classification**

The SC Series Fiber Optic Switch consists of an exposed metal chassis that is connected directly to earth via a power cord and, therefore, is classified as a Class 1 instrument.

The following symbol is used to indicate a protective conductor terminal in the instrument.



### **Before Initializing and Operating the SC Switch**

- Inspect the instrument for any signs of damage.
- Read the User's Manual thoroughly, and become familiar with all safety symbols and instructions to ensure that the instrument is operated and maintained safely.

### **Disconnecting from Line Power**

Some of the SC switch circuits are powered whenever the instrument is connected to the AC power source (line power). To ensure that the switch is not connected to the line power, disconnect the power cord from either the power inlet on the instrument's rear panel or from the AC line-power source (receptacle). The power cord must always be accessible from one of these points. If the switch is installed in a cabinet, the operator must be able to disconnect the instrument from the line power by the system's line-power switch.

<p><b>WARNING</b> To avoid electrical shock, do not initialize or operate the SC switch if it bears any sign of damage to any portion of its exterior surface, such as the outer cover or panels.</p>
---

### **Line Power Requirements**





The SC switch can operate from any single-phase AC power source that supplies between 100 V and 240 V at a frequency range of 50 Hz to 60 Hz. The maximum power consumption of the SC switch is 80 VA.

### **Fuse Type**

The fuse type used by the SC switch is (5x20) mm, T1A / 250 V (slow).

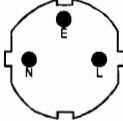
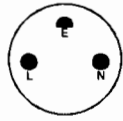
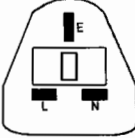
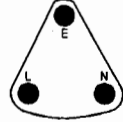
## Line Power Cord

The SC switch uses a three-wire power cord. When connected to an appropriate AC power receptacle, this cable grounds the instrument chassis. JDS FITEL supplies the type of power cord appropriate for the destination country.

Destination	Description	Part Number
Australia		A0102338
Austria, Belgium, Finland, France, The Netherlands, Germany, Portugal, Spain		A0100741
Denmark		A0102681
United Kingdom, Ireland		A0100740
India		A0102180
Israel		A0101407
Italy*		A0100742
North America, Japan, Central America, Columbia, Ecuador, Venezuela		A0100483
Switzerland		A0101406

\* This plug is not polarized.

Note: N (Neutral), E (Earth), L (Line)

**WARNING** To avoid the risk of injury or death, **ALWAYS** observe the following precautions before initializing the SC switch.

- If using a voltage-reducing autotransformer to power the instrument, ensure that the common terminal connects to the earthed pole of the power source.
- Use only the type of power cord supplied with the instrument.
- Connect the power cord only to a power outlet equipped with a protective earth contact. Never connect to an extension cord that is not equipped with this feature.
- Willfully interrupting the protective earth connection is prohibited.

### ***Modifications to the Power Cord***

The power cord can be modified if its plug does not fit the power outlet or if the cord is to be attached to a terminal block. Such a procedure should only be performed by a qualified electrician and in strict compliance with all local electrical codes. The replacement plug end must meet the following specifications:

- adequate load-carrying capacity (see the **General Information and Specifications** section of the User's Manual),
- ground connection, and
- cable clamp.

Refer to the power cord supplied with the SC switch for the colour coding.

### ***Operating Environment***

- WARNING**
- Do not use the SC switch outdoors.
  - To prevent potential fire or shock hazard, do not expose the instrument to any source of excessive moisture.

## Safety Instructions

The following safety instructions must be observed whenever the SC Series Fiber Optic Switch is operated, serviced or repaired. Failing to comply with any of these instructions or with any precaution or warning contained in the User's Manual is in direct violation of the standards of design, manufacture and intended use of the instrument. JDS FIBEL Inc. assumes no liability for the customer's failure to comply with any of these safety requirements.

### ***Classification***

The SC switch consists of an exposed metal chassis that is connected directly to earth via a power cord and, therefore, is classified as a Class 1 instrument.

### ***Before Initializing and Operating the SC Switch***

- Inspect the instrument for any signs of damage, and read the User's Manual thoroughly.
- Install the instrument as specified in the **Getting Started** section of the User's Manual.
- Ensure that the instrument and any devices or cords connected to it are properly grounded.



### ***Operating the SC Switch***

Observe the following instructions to ensure that the SC switch is operated and maintained safely.

- Do not operate the instrument when its covers or panels have been removed.
- Do not interrupt the protective earth grounding. Any such action can lead to a potential shock hazard that could result in serious personal injury.
- Do not operate the instrument if an interruption to the protective grounding is suspected. Ensure that the instrument remains inoperative.
- Use only the type of fuse specified by the manufacturer as appropriate for this instrument. Do not use repaired fuses, and avoid any situation that could short circuit the fuse.
- Unless absolutely necessary, do not attempt to adjust or perform any maintenance or repair procedure when the instrument is opened and connected to a power source at the same time.
- Repairs should only be carried out by a qualified professional.
- Do not attempt any adjustment, maintenance or repair procedure to the instrument's internal mechanism if immediate first aid is not accessible.
- Disconnect the power cord from the instrument before adding or removing any components.
- Operating the instrument in the presence of flammable gases or fumes is extremely hazardous.
- Do not perform any operating or maintenance procedure that is not described in the User's Manual.
- Some of the instrument's capacitors may be charged even when the instrument is not connected to the power source.

## Safety Symbols

The following symbols and messages may be marked on the instrument. Please observe all safety instructions that are associated with a symbol.

	Refer to the User's Manual for instructions on handling and operating the instrument safely.
	Frame or chassis terminal.
	Protective conductor terminal.
<b>WARNING</b>	<b>The procedure can result in serious injury or loss of life if not carried out in proper compliance with all safety instructions. Ensure that all conditions necessary for safe handling and operation are met before proceeding.</b>
<b>CAUTION</b>	The procedure can result in serious damage to or destruction of the instrument if not carried out in compliance with all instructions for proper use. Ensure that all conditions necessary for safe handling and operation are met before proceeding.



## **Safety Information, FCC Radio Frequency Interference Compliance**

---

This equipment has been tested and found to comply with the limits for a Class A digital device, pursuant to Part 15 of the FCC rules. Operation is subject to the following two conditions:

- This device may not cause harmful interference, and
- This device must accept any interference received, including interference that may cause undesired operation.

These limits are designed to provide reasonable protection against harmful interference in a commercial installation. This equipment generates, uses, and radiates radio frequency energy and, if not installed and used in accordance with instructions, may cause harmful interference to radio communications.

**WARNING** Any user modification made to this equipment voids the user's authority to operate this equipment under the FCC rules.

If this equipment is used in a residential setting, resulting interference must be corrected by the user.

The following booklet prepared by the Federal Communications Commission may be helpful, *How to Identify and Resolve Radio-TV Interference Problems*. This booklet is available from the U. S. Government Printing Office, Washington, D.C., 20402. Stock No. 004-00398-5.

## General Information and Specifications

---

### General Information

The SC Series of 1xN programmable switches is designed to connect a single fiber optic input channel to any of N (up to 180) output channels. Its performance, configuration and flexibility are suitable for a wide range of applications, including fiber optic component testing systems, remote fiber test systems in telecommunications, and research and development.

The SC switch connects the input (C) to a selected output channel. The terminations are precisely aligned by a processor-controlled step motor. Collimating lenses terminate the fiber optic attachments, minimizing the insertion loss of the switch and improving the repeatability and stability of its parameters.

The SC switch is equipped with an IEEE 488 parallel interface and an RS232C serial interface for remote control operation. The switch is operated manually at the front-panel controls. The standard SC switch enclosure accommodates up to 90 channels; the double-height enclosure accommodates 180 channels (see **Specifications**, this section).

The SC Series switch is available in a single-common configuration (SC-C) and in dual-common configurations (SC-D and SC-E) which support two (i.e., paired) fiber optic input channels.

### **SC-C Single-common Configuration**

The common input channel (C) is connected to the output channel (1). The reset position (0) of the switch is an open circuit.

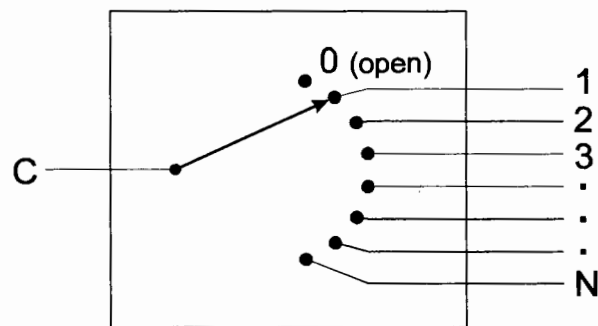

0 = open channel (reset position)

**SC-D Dual-common Configuration**

In this dual-common configuration, channel connections are stepped in pairs. The channel displayed is the current channel pair (A and B). The number of channel pairs is equal to one-half of the total number of channels (N).

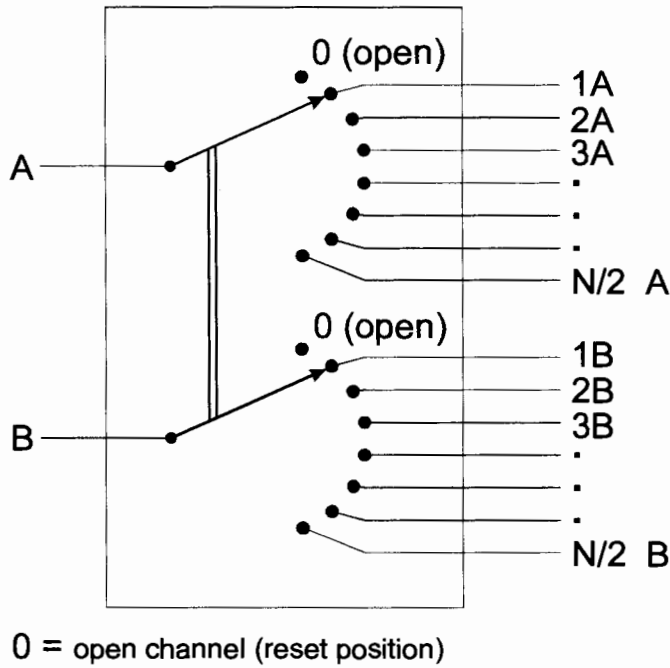

**SC-E Dual-common Configuration**

This configuration allows for single-step movement of paired input channels (A and B). The channel connection displayed is B path, A input channel is connected to B path minus one (1).

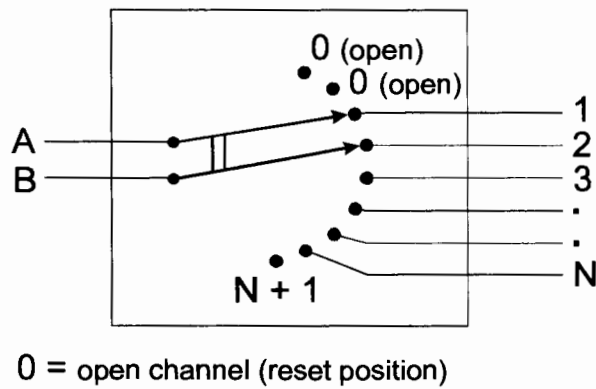

## Specifications

The following optical specifications describe the warranted characteristics of the SC Series Fiber Optic Switch. Supplementary performance characteristics describe the instrument's non-warranted performance.

### Optical Specifications

Parameter	Typical	Maximum
<b>Insertion loss</b> single-mode <sup>1</sup> multimode <sup>1</sup>	0.4 dB 0.3 dB	0.7 dB 0.6 dB
<b>Return loss</b> single-mode <sup>2</sup> multimode	65 dB 25 dB	60 dB (minimum) 20 dB (minimum)
<b>Polarization dependent loss (single-mode)</b>	0.02 dB	0.05 dB
<b>Insertion loss stability<sup>3</sup></b>	± 0.02 dB	± 0.025 dB
<b>Repeatability<sup>4</sup></b> sequential switching random switching	± 0.003 dB ± 0.01 dB	± 0.005 dB ± 0.025 dB
<b>Crosstalk (single-mode)</b>	-100 dB	-80 dB
<b>Input power (continuous wave)</b>	—	300 mW
<b>Channel options</b> front-panel FC or ST connectors front-panel SC connectors 5 m rear-panel pigtail		32 (maximum) 56 (maximum) 90 (maximum)
<b>Switching time</b> on channel each additional channel		300 ms (typical) +12 ms (typical)

<sup>1</sup> Insertion loss does not include connectors. Include 0.2 dB (typical), 0.5 dB (maximum) for each connector.

<sup>2</sup> Excluding connectors.

<sup>3</sup> Drift of any channel relative to one assigned reference channel at ± 3°C deviation of ambient temperature over a seven-day period.

<sup>4</sup> Optimum repeatability after one-hour warm-up.

## Operating Specifications

<b>Local control</b>	<ul style="list-style-type: none"> <li>• Step-up, step-down channel selection</li> <li>• Control of eight relay drivers</li> <li>• IEEE 488.1 address selection</li> <li>• Return-to-local function</li> <li>• Language selection</li> </ul>
<b>Remote control</b>	<ul style="list-style-type: none"> <li>• GPIB interface: IEEE 488.1 1987 capability SH1, AH1, T6, L4, SR1, PP0, DC1, C0, E1</li> <li>• RS232C interface: setting 8 bits, 1200 baud, 1 stop bit, no parity</li> </ul>
<b>Command set</b>	Revised command set. Capable of emulating command set of SC-0 and SX-0 Series switch models.
<b>Drivers</b>	<p>Eight open collector outputs, sink current 100 mA maximum per output (driver):</p> <ul style="list-style-type: none"> <li>• Drivers 1, 2, 3, 4, +5V and GND (ground) are accessible from back panel connector</li> <li>• Drivers 5, 6, 7 and 8 are internal</li> </ul>
<b>Warm-up time*</b>	1 hour at 25°C ambient temperature

\* Applicable for optimum repeatability performance.

## Other Specifications

<b>Electrical</b>	
Input voltage	100 VAC to 240 VAC, 50 to 60 Hz
Power consumption	80 VA maximum
<b>Physical</b>	
Weight single-height double-height	9 kg 14 kg
Dimensions (WxHxD) bench-top single-height with rack-mount* double-height with rack-mount*	44 x 16 x 38 cm 48 x 16 x 38 cm 48 x 32 x 43 cm
<b>Environmental</b>	
Storage temperature	-40°C to 70°C
Operating temperature	0°C to 55°C
Humidity (non condensing)	95% R.H. from 0°C to 55°C

\* Rack-mount kit is optional.

## Getting Started

---

**Read the Safety section of the User's Manual thoroughly before carrying out any of the following instructions.**

### Initial Inspection

**IMPORTANT** Do not discard the original shipping container and packing material. These are required whenever the SC switch is transported and especially when the SC switch is returned to the manufacturer for repairs.

1. Inspect the shipping container for any indication of excessive shock to the contents. Inspect the contents to ensure that the shipment is complete.
2. Visually inspect the SC switch for any damage that may have occurred during shipping.
3. Connect the switch to the AC power source, with the AC power cord provided.
4. Set the power switch to I (on) to initialize the SC switch.

All key lamps and status LEDs will light during the power-up sequence. The model number and the firmware version will be displayed, followed by the active interface command set, the message terminating sequence and the GPIB address. For example, the factory settings for this sequence are *SC (CR LF) 7*, followed by *Channel 0*. If no malfunction is detected during power-up, all lamps and LEDs turn off, and the display will read *0*.

5. Set the power switch to O (off), and disconnect the AC power cord from the AC power supply and from the SC switch.

Immediately inform JDS FITEL and, if necessary, the carrier if the contents of the shipment are incomplete, if the instrument or any of its components are damaged or defective, or if the instrument does not pass the initial inspection.

**WARNING** To avoid electrical shock, do not initialize or operate the SC switch if it bears any sign of damage to any portion of its exterior surface, such as the outer cover or panels.

### Installation

1. Place the SC switch into its intended operating location. The rack-mounting flanges will fully support the weight of the switch.
2. Avoid blocking the ventilation holes at the back and at the bottom of the instrument.
3. Do not pull on the fibers exiting through the rear-panel strain relief. Excessive force could damage the optics.
4. Route the fiber cables in such a way as to avoid creating bends that have a radius of less than 1.5 cm, i.e., cables must not be laid across sharp corners, and bundles of cables should not be tied together tightly.
5. Reattach the AC power cord, and reinitialize the switch.

- |   |
|---|
| <p><b>WARNING</b></p> <ul style="list-style-type: none"><li>• Do not use the SC switch outdoors.</li><li>• To prevent potential fire or shock hazard, do not expose the instrument to any source of excessive moisture.</li></ul> |
|---|

## Operating Environment

In order for the SC switch to meet the warranted specifications, the operating environment must meet the following conditions for temperature, humidity and ventilation.

### Temperature

The SC switch may be operated in the temperature range of 0°C to 55°C.

### Humidity

The SC switch may be operated in environments with up to 95% humidity (0°C to 55°C). Do not expose the instrument to any environmental condition or changes to environmental conditions that can cause condensation to form inside the instrument.

### Ventilation

The SC switch contains a built-in cooling fan. Do not install the instrument in any location where the ventilation is blocked. For optimum performance, the instrument must be operated from a location that provides at least 75 mm (3 inches) of clearance at the rear and at least 25 mm (1 inch) of clearance at the bottom. Blocking the air circulation around the SC switch may cause the instrument to overheat, compromising its reliability.

## Local Control Operation

1. If the REM status LED is lit, press LOCAL once to set the SC switch to LOCAL mode.
2. Press ▲ or ▼ to select the switch position required.
  - ◆ *In SC-E configurations, the display shows the common B switch position. Common A will be set to the display reading, minus one (1).*
3. To toggle a driver, press RELAY and then a numbered key (1 – 8). A driver can be used to operate a 1x2 source select switch. See section 3.0, **Operating and Maintenance Instructions**, for instructions on how to connect an external switch module to the driver connector on the rear panel of the instrument.

## Remote Control – GPIB Operation

1. Connect the SC switch to the GPIB.
2. Verify that the interface command set is set to SC and that the GPIB address is set to 7. To do this, turn the SC switch off and then on again. The display should read *SC (CR LF) 7*. See section 6.0, **Programming Guide**, for instructions on changing the interface command set.
3. At the computer that controls the GPIB, set the message terminating character sequence to carriage return - line feed (<CR><LF>), i.e., ASCII character code 13, 10. The <CR><LF> characters must be appended to the end of any messages sent to the SC switch. Similarly, the switch will append the same characters to all messages it returns.
4. Send a sample command to the SC switch; for example, use an OUTPUT statement (or equivalent) to send the command **CLOSE 10** at GPIB address 7. The channel setting will change to 10. Most programming languages will automatically append the terminating characters to the message.
5. Send a sample query command, for example, **CLOSE?**; then use an INPUT statement to receive the message 10 from GPIB address 7.

## Remote Control – RS232C Operation

1. Connect the RS232C port of the SC switch to a computer, using a cable as described in section 1.0, **Programming Guide**.
2. At the computer, initialize the serial port to 1200 baud, eight bit ASCII character code, one stop bit, and no parity. Use the following MS-DOS<sup>®</sup> Qbasic program as an example.

```
OPEN "COM2;1200,N,8,1" FOR RANDOM AS #1
PRINT #1, "CLOSE 5"
PRINT #1, "CLOSE?"
INPUT #1,A$
PRINT A$
END
```

---

<sup>®</sup> MS-DOS is a registered trademark of the Microsoft Corporation.



# 1.0 External Description

## Front Panel

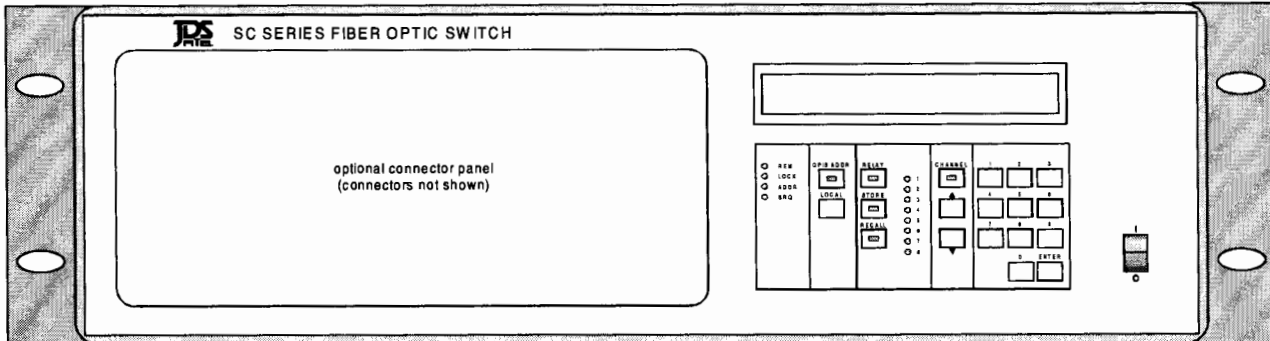

## Operating Keys and Status LEDs

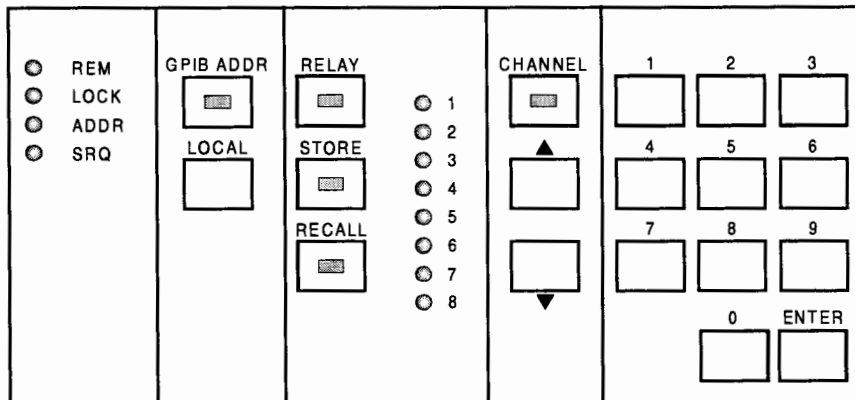

## Operating Keys

I / O	Power on/off switch
GPIB ADDR	Sets the SC switch to GPIB ADDRESS (IEEE 488.1) mode.
LOCAL	Returns the SC switch to LOCAL mode from REMOTE mode, unless the switch is in LOCAL LOCKOUT mode.
RELAY	Sets the SC switch to DRIVER CONTROL mode.
STORE	Stores relay driver patterns in non-volatile memory.
RECALL	Recalls a stored driver pattern.
CHANNEL	Sets the SC switch to CHANNEL CONTROL mode.
▲	Channel increment key
▼	Channel decrement key
□ (0 – 9)	Numbered key pad
ENTER	Terminates an entry, e.g., channel number or GPIB address.

## Status LEDs

<b>REM</b>	Indicates that the GPIB interface is in REMOTE mode. All front-panel keys except LOCAL are locked out.
<b>LOCK</b>	Indicates that the SC switch is in LOCAL LOCKOUT mode. This mode prevents the LOCAL key from returning the SC switch to LOCAL mode.
<b>ADDR</b>	Indicates that the GPIB interface is <i>talk</i> or <i>listen</i> state.
<b>SRQ</b>	Indicates that the interrupt logic of the SC switch has generated a service request interrupt on the GPIB interface.
<b>O (1 – 8)</b>	Indicate the on/off state of the relay drivers (driver is on when LED is lit; off when LED is dark).

## Rear Panel

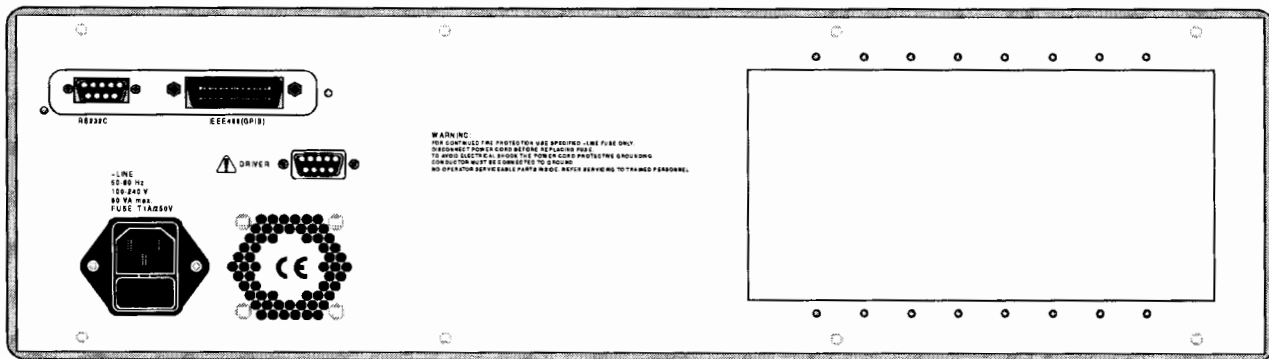

## 2.0 Operating Instructions

---

### Power-up Sequence

1. Connect the switch to the AC power source, with the AC power cord provided.
2. Set the power switch to I (on) to initialize the SC switch.

All key lamps and status LEDs will light during the power-up sequence. The model number and the firmware version will be displayed, followed by the active interface command set, the message terminating sequence and the GPIB address. For example, the factory settings for this sequence are *SC (CR LF) 7*, followed by *Channel 0*. If no malfunction is detected during power-up, all lamps and LEDs turn off, and the display will read *0*.

### Selecting a Channel

- ◆ *Channel numbers entered using the numbered keys are accepted only when the SC switch is set to CHANNEL CONTROL mode.*

1. Press CHANNEL to set the switch to CHANNEL CONTROL mode.
2. Enter the channel number (one to two digits). Single-digit channel numbers, e.g., channel 4, can be entered as *04* or as *4*.
3. Press ENTER.

Or,

- Press ▲ or ▼ to scroll through the channels sequentially.
- ◆ *The ▲/▼ keys can also be used for channel selection while the SC switch is set to RELAY mode.*

In SC-C models (SCXXXX – CXXX), the channel number displayed is the current channel number connected to the common fiber *C* (the switch has one common fiber).

In the SC-D models (SCXXXX – DXXX), the channel number displayed is the current channel pair (the switch has two common fibers).

In the SC-E models (SCXXXX – EXXX), the channel number displayed is the channel connected to the common fiber *B*. The channel connected to the common fiber *A* is *B - 1* (the switch has two common fibers).

- ◆ *In all configurations, channel 0 is an open circuit, i.e., the switch is in an unconnected state.*

## Changing or Verifying the GPIB Interface Address

1. Press GPIB ADDR. The current GPIB address, appended with an asterisk, is displayed.
2. Scroll to the required address using the ▲ or ▼ key, or enter the address via the key pad.
3. Press ENTER to activate the new address. To leave the GPIB address unchanged, press a mode key (GPIB ADDR, RELAY or CHANNEL).

## Setting the Interface Command Set

The SC switch can be set to emulate the interface command sets of earlier models of JDS FITEL SC Series switch models (SCXXXX – 0XXX) and the JDS FITEL SX Series switch.

1. Press and hold LOCAL while the SC switch powers up. The active interface command set is displayed.
2. Press ▲ to scroll to the required command set, i.e., SC, OLD SC or SX.
3. Press a mode key (GPIB, RELAY or CHANNEL) to save the setting.

◆ *The GPIB message terminating characters are also displayed.*

## Controlling the Drivers

The SC switch has four drivers (drivers 1, 2, 3, and 4) for driving the external switch modules and four drivers (drivers 5, 6, 7 and 8) for driving internal switch modules in custom applications. Set the SC switch to RELAY mode to control the drivers.

1. Press RELAY.
2. Enter a number (1 to 8), using the key pad to toggle the corresponding driver on or off. The status LED of the driver lights.

The SC switch has 10 non-volatile memory locations available for storing relay driver patterns.

1. Set the eight drivers individually to the required on/off state.
2. Press STORE.
3. Enter a number using the key pad to assign that number to the pattern.
4. To recall the pattern, press RECALL, followed by the number assigned to the pattern.

## GPIB Interface Pin Assignment

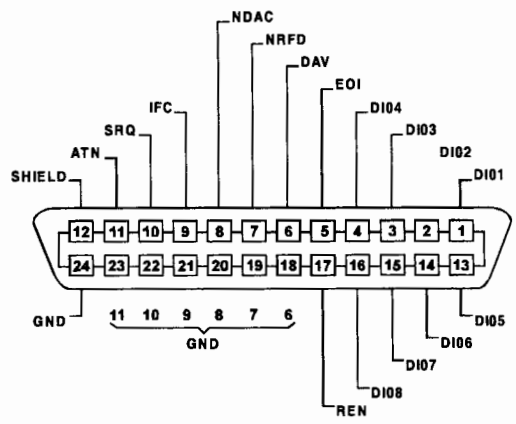

**CAUTION**

- Do not stack more than three connectors on top of each other.
- Tighten the connector lock screws by hand. Do not use a screwdriver.

## RS232C Pin Assignment

*9-pin, D-sub Miniature Receptacle*

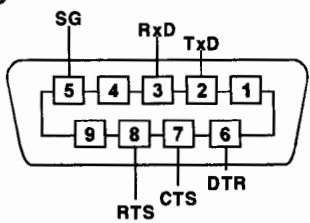

## Driver Pin Assignment

*9-pin, D-sub Miniature Receptacle*

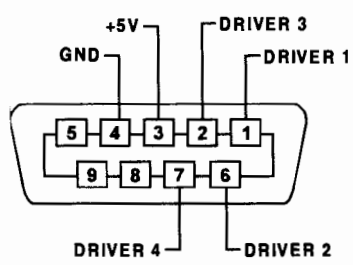

**CAUTION** Do not exceed 100 mA per driver.

## Sample Driver Application

### Electrical Equivalent of Driver

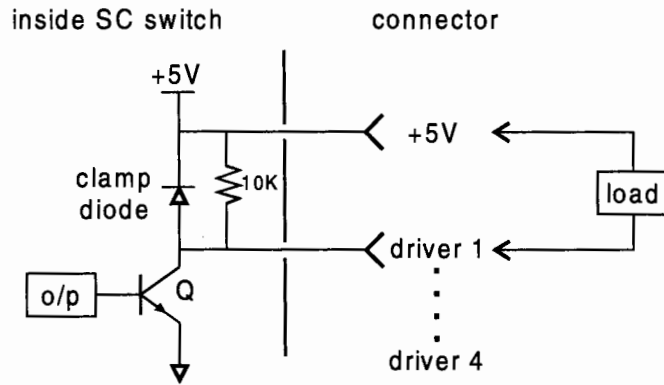

**CAUTION** Do not exceed 100 mA per driver.

### 3.0 External Switch Module Connections

#### External Switch Module Without TTL Logic Input Controls

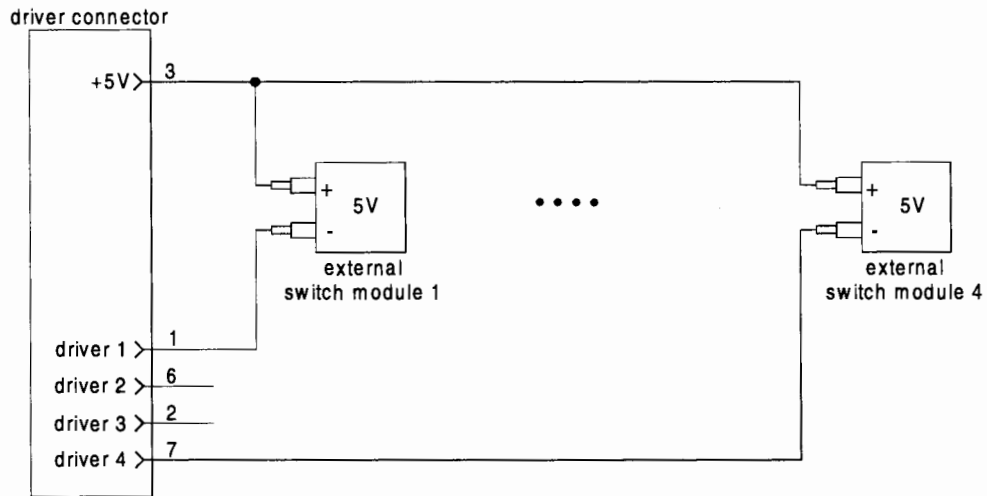

#### External Switch Module With TTL Logic Input Controls

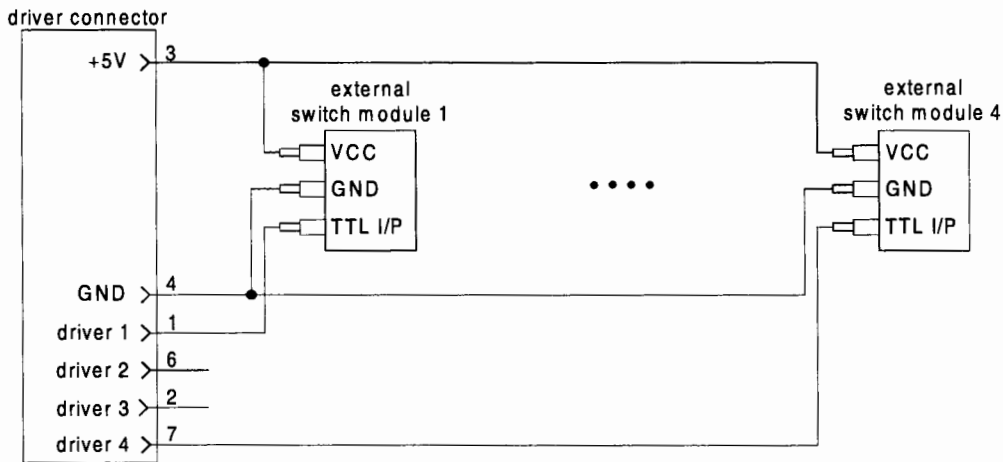

## 4.0 Maintenance and Handling

---

### Maintenance

- ◆ *Clean the connector ends with a lint-free tissue and alcohol before every mating.*
  - ◆ *Clean the internal connectors and the panel-mounted connector bulkheads periodically or when high losses are suspected. The internal connectors can be accessed by removing the connector panel.*
1. Loosen the retaining screws of the connector panel.
  2. Pull the panel out carefully, extending it no more than four (4) inches from the body of the switch.
  3. Remove the connectors from the connector bulkheads.
  4. Clean the connector ends and the bulkhead mating sleeves with a lint-free tissue and alcohol, and reinstall the connectors into the bulkheads.
  5. Reinstall the connector panel, guiding the fiber back to ensure that they do not bend sharply.

<b>CAUTION</b> Do not extend the connector panel more than four (4) inches from the body of the SC switch.
--

### Storing and Shipping

To maintain optimum operating reliability, do not store the SC Series switch in locations where the temperature falls below -40°C or rises above 70°C. Avoid any environmental conditions that can result in internal condensation. Ensure that these temperature and humidity requirements can also be met whenever the instrument is shipped.

### Claims and Repackaging

Immediately inform JDS FITEL and, if necessary, the carrier if the contents of the shipment are incomplete, if the instrument or any of its components are damaged or defective, or if the instrument does not pass the initial inspection. In the event of carrier responsibility, JDS FITEL will allow for the repair or replacement of the instrument or component while a claim against the carrier is being processed.

### Return Shipments to JDS FITEL

JDS FITEL will only accept returns for which an approved Return Material Authorization (RMA) has been issued by JDS FITEL customer service personnel. This number must be obtained prior to shipping any material back to JDS FITEL. The owner's name and address, the model number and full serial number of the instrument, the RMA number and an itemized statement of claimed defects must be included with the return material.



**IMPORTANT** Return material must be shipped in its original shipping container and packing material. If these are not available, ask JDS FIBER customer service personnel to provide packaging instructions.

Typical packaging guidelines are listed below.

1. Cover the front-panel controls with a strip of cardboard.
2. Wrap the instrument in heavy paper or plastic.
3. Use enough shock absorbing material (4- to 6-inch layer around all sides) to cushion the instrument and prevent it from moving inside the container.
4. Ensure that the packing material around the fibers connected to the instrument does not create bends in the fibers with a radius of less than 2.5 cm.
5. Pack the instrument in a reliable shipping container (e.g., a double-wall cardboard box constructed of 350-pound test material).
6. Seal the shipping container securely, and clearly mark FRAGILE on its surface.
7. Always provide the model and serial number of the instrument and, if necessary, the RMA number on any accompanying documentation.

## Programming Guide: Contents

---

<b>1.0</b>	<b>General Information .....</b>	<b>1</b>
	Setting the GPIB Interface Address .....	1
	GPIB Interface Functions .....	1
	RS232C Interface Specifications.....	2
<b>2.0</b>	<b>Operation and Query Commands .....</b>	<b>3</b>
	Command Parser Rules .....	3
	SC Series Switch Operation Commands.....	4
	SC Series Switch Query Commands.....	5
<b>3.0</b>	<b>Status Reporting and Service Request Control .....</b>	<b>7</b>
	Condition Register.....	7
	Status Register.....	7
	SRQ Mask Register.....	8
<b>4.0</b>	<b>GPIB Interface Programming Samples .....</b>	<b>9</b>
	Sending Commands.....	9
	Serial Polling the Status Register .....	10
	Generating a Service Request Interrupt.....	10
	Learn Query (LRN?).....	11
<b>5.0</b>	<b>RS232C Interface Programming Samples .....</b>	<b>12</b>
	Sending Commands.....	12
	Querying Status .....	12
	Reading the Status Register .....	12
<b>6.0</b>	<b>Interface Command Sets .....</b>	<b>13</b>
	SC Series Switch Interface Command Set (SCXXXX – 0XXX Models).....	13
	SX Series Switch Command Set.....	14

## 1.0 General Information

---

The following programming instructions for the SC Series Fiber Optic Switch are intended for users who are familiar with the GPIB interface and how to send or receive messages over the bus. A detailed description of the GPIB interface is contained in *ANSI/IEEE Std. 488.1-1987 IEEE Standard Digital Interface for Programmable Instrumentation*, published by the Institute of Electrical and Electronics Engineers.

The SC switch is equipped with a GPIB parallel interface and an RS232C serial interface. The switch accepts the same device dependent commands, i.e., the commands that control the instrument, over either interface.

The SC switch can be set to emulate the interface command sets, status reporting and service request interrupt control of the SC Series and SX Series switch models. The active interface command set is displayed when the switch is powered on. See **Interface Command Sets**, this section, for instructions on changing the interface command set.

### Setting the GPIB Interface Address

1. Press GPIB ADDR. The current GPIB address, appended with an asterisk, is displayed. (The factory-set GPIB address is 7.)
2. Scroll to the required address using the ▲ or ▼ key, or enter the address using the key pad.
3. Press ENTER to activate the new address. To leave the GPIB address unchanged, press a mode key (GPIB ADDR, RELAY or CHANNEL).

### GPIB Interface Functions

Mnemonic	Function
SH1	source handshake, complete capability
AH1	acceptor handshake, complete capability
T6	basic talker, serial poll, not addressed if MLA
L4	basic listener, not addressed if MTA
SR1	service request capability
RL1	remote/local, complete capability
PP0	parallel poll, no capability
DC1	device clear, complete capability
DT0	device trigger, no capability
C0	controller, no capability
E1	electrical interface, open collector drivers

## RS232C Interface Specifications

Name	Symbol	Pin Number	Signal Direction
transmitted data	TxD	2	out
received data	RxD	3	in
request to send	RTS	8	out
clear to send	CTS	7	in
data terminal ready	DTR	6	out
signal ground	SG	5	

The data protocol is permanently set to 1200 baud, ASCII character code, with eight bits per character, one stop bit and no parity bit. The serial port of the controlling computer must be configured with the same settings.

- ◆ *Use a straight-through cable to connect the SC switch to the serial port of a DTE (computer).*

## 2.0 Operation and Query Commands

---

Operation and query commands control instrument functions and are interface independent.

### Command Parser Rules

- A command consists of a mnemonic (e.g., CLOSE) and, if required, a data parameter. The mnemonic and the data parameter must be separated by at least one space.
- Parameters can be entered in various formats; for example, 10, 10.0 and 1.0e1 are all recognized as the same value.
- Commands can be sent in uppercase or lowercase characters.
- A command is transmitted in a message, and messages can contain more than one command. For example, **CLOSE 6;XDR 2 1 <CR> <LF>** contains two commands.
- All GPIB messages must end with the terminating sequence <CR> <LF>.
- All RS232C commands must be terminated with a single <CR> character.
- The input buffer of the SC switch can hold as many as 100 characters. If the buffer becomes full, the switch will hold the handshaking line on the GPIB interface until space is available. Similarly, over the RS232C interface, the SC switch will set the **Clear To Send** line low. Any characters received after the line goes low are ignored.
- Commands are executed as they are parsed; consequently, a command may be executed before the entire message in which it is contained is received.
- The SC switch will delay accepting new characters sent over the GPIB interface while the switch mechanism is moving; however, no data will be lost. The SC switch is always ready to accept characters over the RS232C interface.
- A query command is used to extract status information from the SC switch. For example, **SRE? <CR> <LF>** returns the contents of the status register (see **Status Reporting and Service Request Control**, this section).
- Multiple-command messages can contain only one query command. A query must be the last command in the message, for example, **CLOSE 20; XDRS? <CR> <LF>**.

## SC Series Switch Operation Commands

**RESET**

**Reset**

Returns the SC switch to the power-up state, i.e., channel 0, relay drivers off.

**CLOSE *i***

**Set Optical Channel**

Closes the optical path represented by the integer *i*.

**XDR *i k***

**Driver Control**

Sets the specified external driver on or off.

- *i* = the driver number (1 – 8)
- *k* = 1 (on)
- *k* = 0 (off)

**XDRS *i***

**Drivers Control**

Sets all eight relay drivers according to the binary conversion of *i*. The binary weight of the drivers is as follows.

- driver 1 = 1
- driver 2 = 2
- driver 3 = 4
- driver 4 = 8
- driver 5 = 16
- driver 6 = 32
- driver 7 = 64
- driver 8 = 128

Add together the weights of the drivers to be activated, and send the total, e.g., when *i* = 255, all eight relay drivers are turned on.

**SRE *i***

**Clear Status Byte**

Writes a decimal number to the SRQ mask register (see **Status Reporting and Service Request Control**, this section). Setting a bit to 1 will generate an SRQ interrupt when the corresponding bit in the status register changes from 0 to 1.

**CSB**

**Clear Status Byte**

Resets the status byte.

**CLR**

**Clear Device**

Clears the SRQ mask register and the status register.

## SC Series Switch Query Commands

**CLOSE?**

**Optical Switch Path**

Returns the current optical path number. If the switch has two common input fibers (A and B), **CLOSE?** returns the position of fiber B. **CLOSE? MAX** returns the maximum channel number.

**XDR? i**

**Driver**

Returns the state of an external relay driver (i).

- 0 = relay driver is off
- 1 = relay driver is on

**XDRS?**

**Drivers**

Returns the states of all drivers in a binary-coded integer.

**LRN?**

**Learn**

Returns a string containing three commands which, if sent, reset the switch to its current state, e.g., **CLOSE i;XDRS k;SRE l**, where *i* represents the current path number, *k* represents the states of the external drivers, and *l* represents the value of the service request enable register.

**STB?**

**Status Register**

Returns a three-digit integer and automatically clears the status register if the SRQ bit is set.

**SRE?**

**SRQ Mask**

Returns the contents of the SRQ mask register.

**CNB?**

**Condition Register**

Returns the contents of the condition register.

**TST?**

**Self-test**

Executes a self-test operation. An error code that can be queried with **ERR?** or **LERR?** is placed in an error queue. The query **TST?** also sets Bit 7 in the status register.

- 0 = self-test passed
- 1 = self-test failed

**ERR?****Error Number**

Returns an error number if the self-test fails.

- 330 = self-test failed
- 0 = self-test did not fail

**LERR?****Last Number Error**

Returns a three-digit error number from the error queue. The queue can contain as many as five error numbers. The first error read is the last error that occurred. **LERR?** returns 000 if the error queue is empty.

**OPC?****Operation Complete**

Returns the status of the input buffer.

- 1 = the input buffer is empty, i.e., all commands have been executed
- 0 = the input buffer is not empty, i.e., commands are still pending

**IDN?****Identifier**

Returns a string that identifies the manufacturer, the SC Series switch model number and the firmware level, i.e., JDS FITEL INC., SC Switch, 2.00.



### 3.0 Status Reporting and Service Request Control

---

The SC switch maintains three, eight-bit registers that are used for status reporting and for enabling the GPIB service request interrupt:

- the condition register,
- the status register, and
- the SRQ mask register.

#### Condition Register

The condition register monitors the current state of the switch mechanism. Bit 2, the settled condition bit, is 1 when the switch mechanism has stopped at the desired channel and 0 when the switch is moving to a new output channel. The **CNB?** query command returns the value of the condition register. When the settled bit is true, **CNB?** will return 4.

Condition Register							
Bit 7	Bit 6	Bit 5	Bit 4	Bit 3	Bit 2	Bit 1	Bit 0
0	0	0	0	0	Settled	0	0

#### Status Register

The status register records errors and other events that have occurred in the SC switch. When an event occurs, the status logic of the SC switch sets the corresponding bit to 1. This register can be read at any time because the bits will stay set until the register is read at least once.

Status Register							
Bit 7	Bit 6	Bit 5	Bit 4	Bit 3	Bit 2	Bit 1	Bit 0
Self-test Error	Service Request	Syntax Error	Message Available	0	Settled	0	Parameter Error

- Bit 7 (Self-test Error) is set if a calibration error is detected after power-up or after the self-test query (**TST?**) is executed. At all other times it is 0.
- Bit 6 (Service Request) is set when the interrupt request logic of the SC switch detects a reason to generate a service request interrupt on the GPIB interface.
- Bit 5 (Syntax Error) is set when the parser detects a syntax error in a command mnemonic.
- Bit 4 (Message Available) is set when a message is available in the output buffer.
- Bit 2 (Settled) is set when Bit 2 in the condition register changes from 0 to 1.
- Bit 0 (Parameter Error) is set when a parameter value is out of the range of the SC switch.

The status register can be read with the status register query (**STB?**) or by serial polling the GPIB interface. During power-up, the status register contains 0 and can only be read by serial polling. After initial power-up, only the settled bit (Bit 2) is set to 1. The clear status byte command (**CSB**) and the clear device command (**CLR**) clear the status register. **STB?** also clears the status register but only if the service request bit (Bit 6) is set to 1.

### SRQ Mask Register

The SRQ mask register unmask specific events in the status register that will generate service request interrupts on the GPIB interface. The SRQ mask command (**SRE**) writes to the SRQ mask register. When a bit in the SRQ mask register is set to 1, the interrupt logic of the switch will monitor the corresponding event bit in the status register; an SRQ is generated and Bit 6 in the status register is set when the corresponding bit changes from 0 to 1.

The SRQ mask register can unmask more than one event at a time. The first unmasked event to change from 0 to 1 causes an interrupt. To acknowledge this interrupt, the GPIB interface can be serial polled or the status register can be read with **STB?**. The first time the SC switch is serial polled after an SRQ is generated, Bit 6 will be on. Subsequent serial polling returns a value with Bit 6 off. Similarly, **STB?** returns the status register with the SRQ bit set, but then the logic of the SC switch automatically clears the register. As a result, subsequent **STB?** queries return 0.

The SRQ mask register is cleared by powering up the SC switch, by the clear device command (**CLR**) or by the universal device clear command (**DC1**).

SRQ Mask Register							
Bit 7	Bit 6	Bit 5	Bit 4	Bit 3	Bit 2	Bit 1	Bit 0
Self-test Error	n/a	Syntax Error	Message Available	n/a	Settled	n/a	Parameter Error

## 4.0 GPIB Interface Programming Samples

---

This section provides programming samples for controlling the SC switch over the GPIB interface. The samples were written in MS-DOS Qbasic and run on a PC-compatible computer, equipped with a NATIONAL INSTRUMENTS® GPIB interface board, and with NATIONAL INSTRUMENTS Universal Language Interface drivers loaded. The commands that control the GPIB are very similar to HEWLETT PACKARD® HP Basic commands. Most other controller board manufacturers provide basic output and input statements for communicating messages to a GPIB instrument.

- ◆ *The GPIB commands provided in this section do not always show the terminating sequence <CR><LF>; however, it is implied.*
- ◆ *Before using any of these samples, ensure that the GPIB address is set to 7, the interface command set is SC, the ULI.EXE driver is loaded, and the switch is connected to the computer via a GPIB cable.*

### Sending Commands

This sample sets the SC switch to channel 6 and turns on all the external relay drivers.

```
'setup the interface card and drivers
OPEN "GPIB0" FOR OUTPUT AS #1
OPEN "GPIB0" FOR INPUT AS #2
PRINT #1, "ABORT"
'set terminating character to CR LF sequence."
PRINT #1, "GPIBEOS OUT CR LF"
PRINT #1, "GPIBEOS IN CR LF"
'sample commands"close 6; xdrs 255'
PRINT #1, "OUTPUT 07;CLOSE 6;XDRS 255"
'sample queries
PRINT #1, "OUTPUT 07;CLOSE?"
PRINT #1, "ENTER 07"
INPUT #2, a
PRINT "channel ",a
PRINT #1, "OUTPUT 07;XDRS?"
PRINT #1, "ENTER 07"
INPUT #2, a
PRINT "driver state ",a
END
```

---

® NATIONAL INSTRUMENTS is a registered trademark of the National Instruments Corporation.

® HEWLETT PACKARD is a registered trademark of the Hewlett-Packard Co.

## Serial Polling the Status Register

This sample changes the channel setting and reads the status register continuously until the output has settled.

```
PRINT #1, "OUTPUT 07;csb"      ' clearing the status byte clears the settling bit
PRINT #1, "OUTPUT 07;CLOSE 12" ' change channel
sr = 0                          ' initialize sr variable to enter the while loop
WHILE ((sr AND 4) =0)          ' loop until settled bit is true
  PRINT #1, "SPOLL 07"         ' serial poll SC
  INPUT #2, sr
WEND
PRINT sr                        ' print final value of sr
END
```

## Generating a Service Request Interrupt

This sample tests the service request interrupt function. It unmask the settled bit in the SRQ mask register and selects a channel. An interrupt is generated when the SC switch reaches the channel.

```
ON PEN GOSUB SPOLL             ' ENABLE SRQ INTERRUPT
PEN ON
PRINT #1, "OUTPUT 07;CSB;SRE 4" ' CLEAR STATUS REGISTER AND UNMASK
                                ' SETTLED BIT IN SRQ MASK REGISTER
PRINT #1 "OUTPUT 07;CLOSE 6"   ' CHANGE CHANNEL
' More code executed while switch channel set
'
'
WHILE (INKEY$ = "")            ' endless loop to simulate bigger program
WEND                            ' ends when any key is pressed
PEN OFF
END

SPOLL:
  PRINT #1, "SPOLL 07"         ' serial poll SC
  INPUT #2, sr                 ' read status register
  PRINT sr                     ' verify SRQ bit is set
  PRINT #1, "SPOLL 07"         ' serial poll again to verify SRQ bit is now
  cleared
  INPUT #2, sr                 ' read status register
  PRINT sr
RETURN
```

## Learn Query (LRN?)

This sample demonstrates the use of the learn query.

```
DIM LEARN$(100)
PRINT #1, "OUTPUT 07;LRN?"      ' send the learn query command
PRINT #1, "ENTER 07"
LINE INPUT #2, LEARN$
' The above variables could be saved in a data file before quitting the program and
' then later read back and used to restore the SC to a same state.
' Like this...
PRINT#1, "OUTPUT 07;"LEARN$
'SC settings are now restored
END
```

## 5.0 RS232C Interface Programming Samples

---

This section provides programming samples for controlling the SC switch over the RS232C interface. The samples were written in MS-DOS Qbasic and run on a PC-compatible computer, equipped with a serial port. COM port 2 of the computer is designated as the serial port and is connected to the SC switch.

- ◆ *Before using any of these samples, ensure that the active interface command set is SC.*
- ◆ *The RS232C commands that appear in this section do not always show the terminating character <CR>; however, it is implied.*
- ◆ *The RS232C interface cannot receive an SRQ interrupt.*

### Sending Commands

```
OPEN "COM2:1200,N,8,1: FOR RANDOM AS #3
A = 10
PRINT#3, "CLOSE ";A
PRINT#3, "XDRS 255"
END
```

### Querying Status

This sample queries and displays the current channel setting.

```
PRINT#3, "CLOSE?"
INPUT#3, A
PRINT A
END
```

### Reading the Status Register

The serial polling function is not supported on any RS232C interface, but **STB?** can be used to query the status register because the query command performs the same function as serial polling.

The following sample changes the channel setting and reads the status register continuously until the output has settled.

```
OPEN "COM2:1200,N,8,1" FOR RANDOM AS #3
PRINT#3, "CSB"           'clear Status Register
PRINT#3, "CLOSE 5"
DO                       'loop until motor settles
    PRINT#3, "STB?"
    INPUT#3, SR1
LOOP UNTIL (SR1 AND 4)
PRINT SR1
END
```

## 6.0 Interface Command Sets

The SC switch can be set to emulate the interface command sets of earlier models of JDS FITEL SC Series switches (SCXXXX – 0XXX) as well as the JDS FITEL SX Series switches.

1. To change the command set, press and hold LOCAL while the SC switch powers up. The active interface setting is displayed.
2. Press ▲ to scroll to the required command set, i.e., SC, OLD SC or SX.
3. Press GPIB ADDR to save the setting.

### SC Series Switch Interface Command Set (SCXXXX – 0XXX Models)

Syntax	Function
AnE	Switch to channel <i>n</i>
FE	Verify channel
XE	Turn driver on
YE	Turn driver off

Response messages are formatted as *qn*, where *q* is the switch status (*A* = normal, *I* = syntax error, *C* = calibration error), and *n* is the channel number.

Status Byte Register							
Bit 7	Bit 6	Bit 5	Bit 4	Bit 3	Bit 2	Bit 1	Message
0	0	0	0	0	0	0	BUSY
0	0	0	0	0	0	1	NORMAL
0	RQS	0	0	0	0	1	CAL ERROR
0	RQS	0	0	1	0	1	BAD DATA
0	RQS	0	0	1	1	1	UNIT FAILURE

## SX Series Switch Command Set

Syntax	Function
An	Switch to channel <i>n</i>
Sn	Set driver <i>n</i>
Cn	Clear driver <i>n</i>
Bk	Configure drivers with binary code <i>k</i>
E	Enable unit to assert SRQ interrupt after completing each command
D	Disable SRQ interrupt except when an error occurs
R	Remote mode: lock out front panel keys Not implemented in SC switch (RS232C only)
L	Local mode: enable front panel keys Not implemented in SC switch (RS232C only)

Response messages are formatted as *qn Rm*, where *q* is the unit status (*A* = normal, *C* = command error, *S* = system error); *n* is the channel number (0 to N); *R* is the letter *R*; and *m* is the state of the external relay drivers (0 to 255).

Status Byte Register								Message
Bit 7	Bit 6	Bit 5	Bit 4	Bit 3	Bit 2	Bit 1	Bit 0	
0	RQS	0	0	0	0	0	0	BUSY
0	RQS	0	0	0	0	0	1	NORMAL
0	RQS	1	0	0	0	0	1	BAD DATA
0	RQS	1	0	0	0	1	0	UNIT FAILURE

These bits are usually set to 0. Bit 6 (RQS) is set to 1 when the SC switch generates a service request interrupt.



20 December 1995  
France

## EC DECLARATION OF CONFORMITY

We, JDS FITEL (Europe)  
10 Avenue du Québec  
BP537  
91946 Courtaboeuf Cedex  
France  
Contact: Bertrand Visseaux

Phone: 011-33-1-6446-0841  
Fax: 011-33-1-6446-0845

declare under our sole responsibility that our **SC SERIES OF OPTICAL SWITCHES** to which this declaration relates are in conformity with the following standards:

EN50082-1 (1992)

EN50081-1 (1992)

EN66055

per the provisions of the **Electromagnetic Compatibility Directive 89/336/EEC** of 3 May 1989 as Amended by **92/31/EEC** of 28 April 1992 and **93/68/EEC, Article 5** of 22 July 1993 and,

EN61010

per the provisions of the **Low Voltage Directive 73/23/EEC** of 19 February 1973 as Amended by **93/68/EEC, Article 13** of 22 July 1993.

The Technical documentation required by Annex IV(3) of the Low Voltage Directive is maintained by :

JDS FITEL (Europe)  
10 Avenue du Québec  
BP537  
91946 Courtaboeuf Cedex  
France  
Contact: Bertrand Visseaux

The manufacturer of this product is:

JDS FITEL Inc.  
570 West Hunt Club Road  
Nepean, Ontario  
CANADA K2G 5W8

Phone: +(1)-613-727-1303  
Fax: +(1)-613-727-8284

Authorized Signing Authority : *Bertrand Visseaux*

*Dec 26<sup>th</sup>, 1995*  
Date:

ENG-FM-0036  
Rev. A

SALES INQUIRIES (613) 727-1303 GENERAL INQUIRIES (613) 727-1304 FAX (613) 727-8284  
570 WEST HUNT CLUB ROAD, NEPEAN, ONTARIO, CANADA K2G 5W8

**Factory Performance Test Record**

Tested By	Irina			Date(yyyy/mm/dd)	1999/05/10		
Model #	SC1C10201+17AF000FA			Serial #	MC013832		
				S/O #	153596		
Temp. [C]	23	Humidity	34%	<input checked="" type="checkbox"/> SM	<input type="checkbox"/> MM	Core/Cladding size:(um)	9/125
Number of Common	1			Number of Outputs	20		
Number of 1x2 Switch Module:				Number of 2x2 Switch Module			
Number of _x_ Switch Module:				Connector Type	FC/APC		
Calibration Wavelength(s)			1). 1300nm	2). 1550nm	3).		
Additional Product Information:							

**Log of Results**

Motor Switch Common:           C          

Spec.		Insertion loss (dB)			PDL (dB)/SM Only			Return Loss (dB)		
		1.1			0.05			65		
Display	Chan. #	1300nm	1550nm		1300nm	1550nm		1300nm	1550nm	
1	1	0.7	0.5		0.02	0.02		65.3	66.2	
2	2	0.4	0.4		0.02	0.02		65.4	66.5	
3	3	0.5	0.4		0.02	0.02		65.2	66.3	
4	4	0.5	0.4		0.02	0.02		65.3	66.6	
5	5	0.7	0.5		0.03	0.02		65.6	66.4	
6	6	0.5	0.4		0.02	0.02		65.3	66.5	
7	7	0.5	0.4		0.04	0.03		65.4	66.3	
8	8	0.7	0.5		0.02	0.01		65.2	66.6	
9	9	0.6	0.4		0.01	0.01		65.8	66.2	
10	10	0.7	0.6		0.02	0.01		65.6	66.3	
11	11	0.7	0.6		0.02	0.01		65.3	66.3	
12	12	0.7	0.5		0.03	0.01		65.4	66.3	
13	13	0.6	0.5		0.02	0.01		65.5	66.2	
14	14	0.6	0.4		0.03	0.01		65.5	66.1	
15	15	0.7	0.6		0.02	0.01		65.3	66.3	
16	16	0.6	0.5		0.02	0.02		65.5	66.2	
17	17	0.5	0.4		0.03	0.01		65.2	66.5	
18	18	0.7	0.5		0.03	0.01		65.6	66.3	
19	19	0.8	0.6		0.02	0.01		65.4	66.1	
20	20	0.7	0.5		0.03	0.01		65.4	66.2	

Use additional sheets, expand this form if required for more channels

Comments: (e.g. whether connector loss is included or not and connector type)  
 Connectorized switch loss includes internal switch loss and two connectors.

Checked By:           Anh Le           Date (yyyy/mm/dd):           1999/05/10